

Special Devices

The following devices have been designed for general application purposes in an industry wide format. In all cases, Contact Tooling is NOT included with a standard order. In addition, minor modifications of the components may be required to achieve desired results. In all cases, thorough engineering is required by the customer to insure final functionality.

All of the following special devices are ordered as a KIT and will be shipped completely assembled or as much as possible. This allows the customer to attach tooling and mount directly to the conveyor.

For questions please contact Mod Tech.

Metering/Stopping Devices

MAC-4390 HORIZONTAL METER SINGLE ARM KIT

Application: Metering or Stopping pallets or product on conveyor.

Features: Retracting the cylinder releases a part at the same time stops the next. Extending the cylinder allows the next part to move into the release area. Components attach directly to the tooling slot in the conveyor rail.

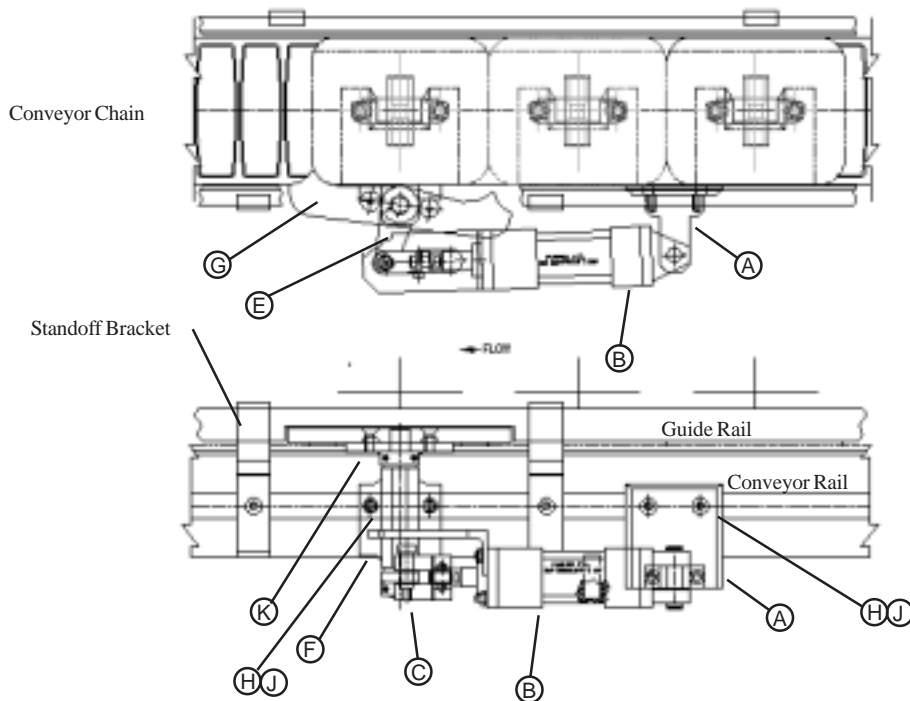

Note: The tooling arm is not included in the package.

DESCRIPTION	QTY	INCLUDED
A ANCHOR MOUNTING BRACKET	1	YES
B CYLINDER WITH PROX BRACKET	1	YES
C CYLINDER ROD CLEVIS	1	YES
D PIVOT ARM	1	YES
E METER HOUSING	1	YES
F METER ARM MOUNTING BRACKET	1	YES
G TOOLING ARM	1	NO
H 5/16-18 X 1.00: LG. BHSCS	4	NO
J 5/16-18 SPRING NUT	4	NO
K 5/16-18 X .88" LG. FHSCS	2	NO

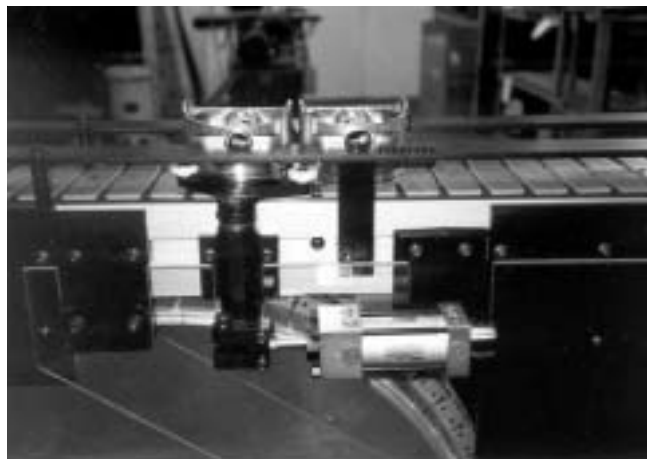

Metering/Stopping Devices

MAC-4391

HORIZONTAL METER DOUBLE ARM KIT

Application: Metering or Stopping pallets or product on conveyor.

Features: Retracting the cylinder releases a part at the same time stops the next. Extending the cylinder allows the next part to move into the release area. Components attach directly to the tooling slot in the conveyor rail.

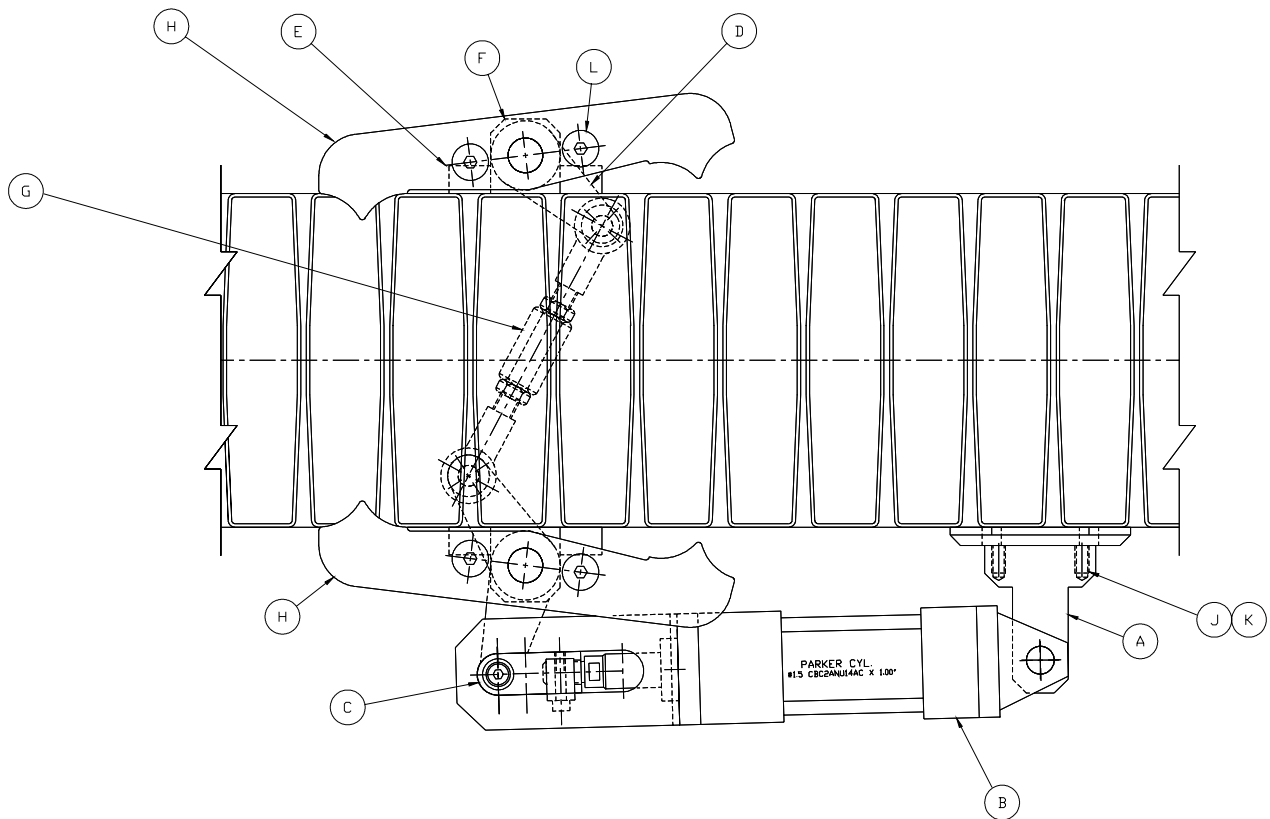

DESCRIPTION	QTY	INCLUDED
A ANCHOR MOUNTING BRACKET	1	YES
B CYLINDER WITH PROX BRACKET	1	YES
C CYLINDER ROD CLEVIS	1	YES
D PIVOT ARM	2	YES
E METER HOUSING	2	YES
F METER ARM MOUNTING BRACKET	2	YES
G LINKAGE AND HARDWARE	1	YES
H TOOLING ARM	2	NO
J 5/16-18 X 1.00: LG. BHSCS	6	NO
K 5/16-18 SPRING NUT	6	NO
L 5/16-18 X .88" LG. FHSCS	4	NO

Metering/Stopping Devices

MAC-4392

VERTICAL METER KIT

Application: Metering or Stopping pallets or product on conveyor.

Features: Retracting the cylinder releases a part at the same time stops the next. Extending the cylinder allows the next part to move into the release area. Components attach directly to the tooling slot in the conveyor rail.

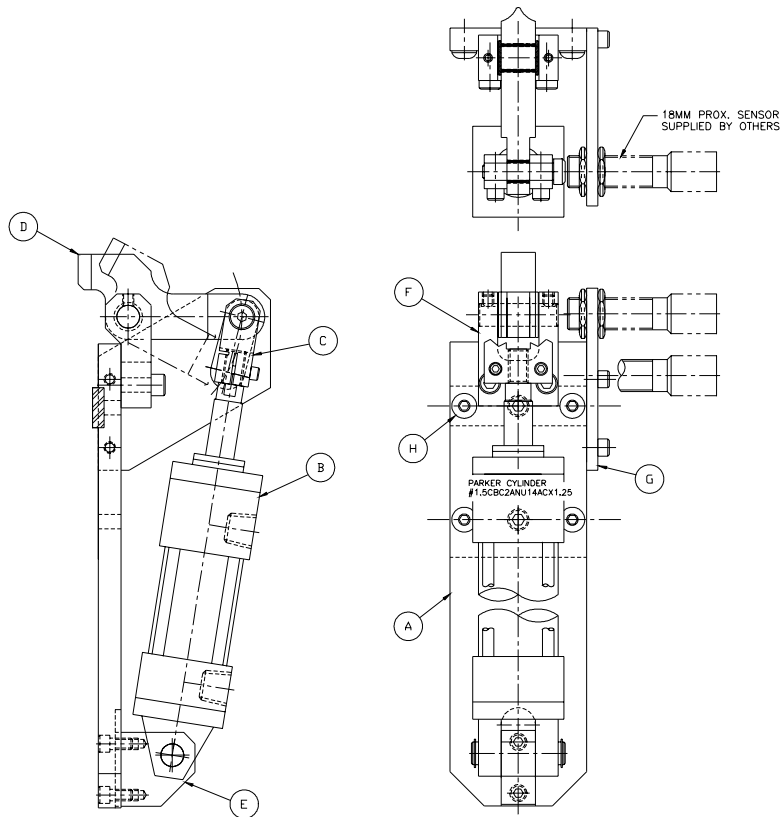

DESCRIPTION	QTY	INCLUDED
A METER MOUNTING BRACKET	1	YES
B CYLINDER WITH PROX BRACKET	1	YES
C CYLINDER ROD CLEVIS	1	YES
D PIVOT ARM	1	YES
E MOUNTING CLEVIS	1	YES
F METER ARM MOUNTING BRACKET	1	YES
G PROX BRACKET	1	YES
H 5/16-18 X 1.00: LG. BHSCS	2	NO
J 5/16-18 SPRING NUT	2	NO

NOTE: The pivot arm (item D) is supplied in standard form. Any modifications needed for specific applications are the responsibility of the customer.

Lift and Locate Device

MAC-4393 PALLET L&L KIT

Application: Lift and locate stopped pallets on a conveyor for precision automation operations such as robotics assembly.

Features: Designed to work with specially designed pallets using "V" grooves in the pallet. Accuracies and repeatability are a function of the end tooling (not supplied) and the pallet design.

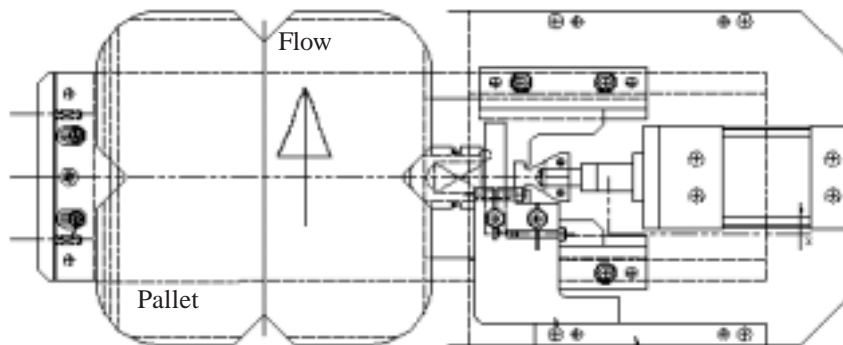

Contact Mod-Tech for specific needs.

